



**Products:** Leaf Beater® Original with Clean Shield™

**Code:** RHLB01 – 90mm  
RHLB02 – 100mm

The Original Compact Rain Head - now with Enhanced Performance

## Product Description

Keeps your Rain Harvesting system free of mosquitoes, vermin and debris.

The Leaf Beater® Original + Clean Shield™ is the practical and versatile Rain Head, featuring the new patented Clean Shield™ (single screen) technology. The Leaf Beater® Original + Clean Shield™ Rain Head prevents debris from entering the Rain Harvesting system, improves water quality and reduces tank maintenance. The single screen incorporates Clean Shield™ technology which deflects leaves and debris away from the flow of water. This minimises maintenance and enhances catchment efficiency.

## Features and Benefits

- Upgraded with new debris shedding single screen technology (Clean Shield™)
- Enhanced catchment efficiency – collect more rainwater
- Minimal maintenance – screen automatically sheds debris
- Higher flow rate performance
- Compact design suits smaller spaces
- A single mosquito proof stainless steel mesh screen with 0.955mm aperture
- Available in 90mm or 100mm outlet

## Compliance

- Queensland Development Code MP 4.2 – Water Saving Targets
- AS/NZS 3500.3:2003 Plumbing and Drainage – Stormwater Drainage
- HB230:2008 Rainwater Tank Design and Installation Handbook
- enHealth Council – Guidance on the Use of Rainwater Tanks – Preventing Mosquitoes Breeding
- Queensland Health Regulations 1996 (Part 8 – Mosquito Prevention)

## Installation

### Gutter Installation

1. Remove the existing Gutter Outlet from the roof guttering system.
2. Hold the new Gutter Outlet #3 against the fascia and the bottom of the gutter where the new outlet hole is to be, then using the gutter outlet as a template, draw around the inside of the outlet to mark the underside of the gutter for the new hole and cut out with tin snips.
3. Refit the Gutter Outlet #3 to the main body #1 and place a small amount of sealant in the sealant groove in #3.
4. Remove the Clean Shield™ screen #2 whilst fitting the Leaf Beater® Original. Simply lift the Clean Shield™ screen out (figure 4) by taking hold of the quick release tabs (red) and pull them outwards and upwards.
5. Slide the Leaf Beater® Original up against the fascia and position the Outlet #3 over the gutter outlet hole. Fasten the unit to the fascia with two rivets or screws through the back of the body #1 and into the fascia.
6. Insert the Clean Shield™ screen #2 into the rain head at approx 45 degrees (figure 1) until the front rubber channel is nearly over the front lip of the body. TIP : Wetting the rubber seal will help the screen slide into place.
7. Fix the front of the Clean Shield™ screen #2 into place (figure 2) by sliding the rubber channel (red) over the front lip (green) of the body.
8. Reaching towards the back of the screen push down on the plastic frame (figure 3) so that the rear edge (red) is below the lowest notch (green) and firmly against the back wall of the Leaf Beater® Original.
9. The Leaf Beater® Original is now ready for connection to the downpipe. Do NOT glue the Leaf Beater® Original to the downpipe. SECURE with a screw for easy replacement.

**NOTE:** Where gutters are stretched out or out of square it may be necessary to rivet the Outlet #4 to the gutter. Take care to ensure the Outlet #4 is sealed to the gutter in all situations.

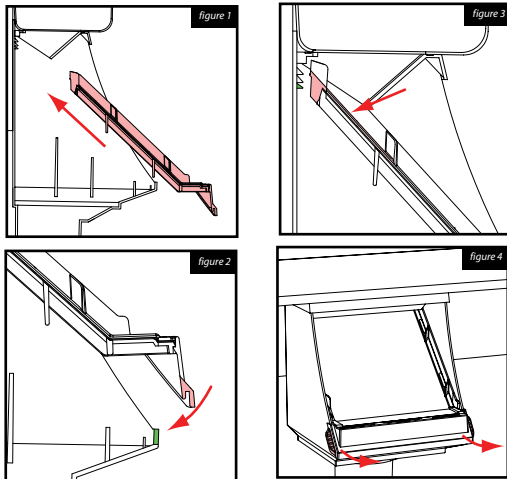

### Mid-Mount Installation

To improve access for cleaning the Leaf Beater® Original Rain Head can be mounted down the wall at a convenient height.

It is important to note that when mid-mounting, the flow directional benefits of the rectangular gutter outlet supplied with the Leaf Beater® Original will be lost. However this is to be balanced with the benefits gained from easier access for maintenance.

For mid-mounting, discard the top flow-directional gutter outlet. Cut the entry downpipe and install so that the downpipe sits approximately 5mm below the inside top edge of the Leaf Beater® Original body. This ensures the end of the pipe is within the Leaf Beater® Original and water is directed onto the face of the screen.

**Recommendation:** When mounting the Leaf Beater® Original, make sure that it is mounted minimum of 1.2m above the discharge point when pushing water underground and then up into a tank. Long runs may require more than a 1.2m head depending on the pipe length and size of the pipe and the volume required to be moved.

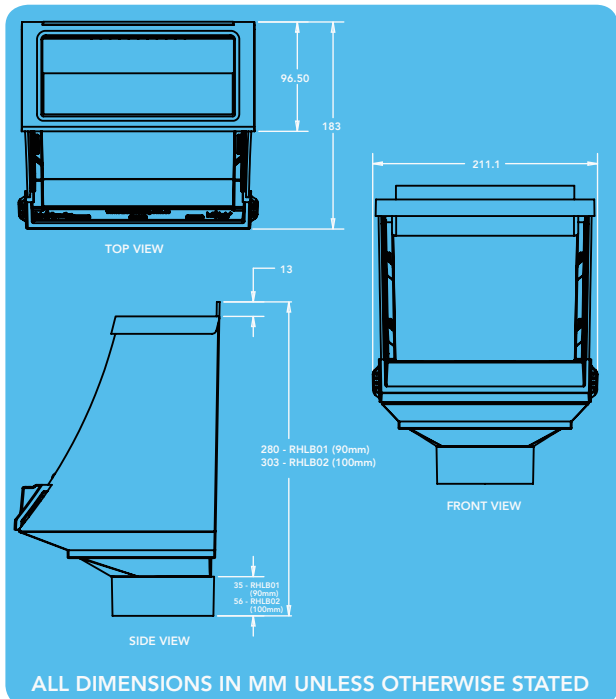
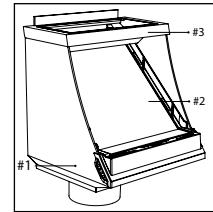

## Maintenance

The Clean Shield™ screen is mostly self cleaning. If cleaning is required simply lift the Clean Shield™ screen out by taking hold of the quick release tabs and pull the Clean Shield™ screen upwards and outwards, then hose or brush off.

PO237 DISCLAIMER This product specification is not a complete guide to product usage. Further information is available from Rain Harvesting Pty Ltd and from the Installation and Operating Instructions. This specification sheet must be read in conjunction with the Installation and Operating Instructions and all applicable statutory requirement. Product specifications may change without notice. © Rain Harvesting Pty Ltd